

MESS-20 series

MINIATURE ELECTRIC CYLINDER (WITH MOTOR)

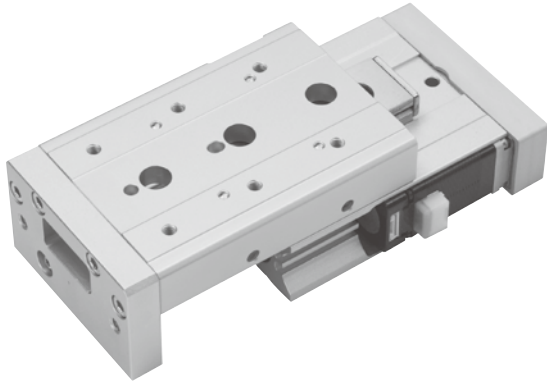

mindman



Specification

Model	MESS-20	
Repeatability (mm)	±0.02	
Ball screw lead (mm)	1	6
Maximum speed (mm/s)*	50	250
Maximum payload	Horizontal (kg)	6
	Vertical (kg)	2
Rated thrust (N)	466	75
Stroke (mm)	30 / 50	
Motor dimension (mm)	□25	
Ball screw spec (mm)	C10ø6	

* The maximum speed shown here is when software speed setting is 100%.

Order example of cylinder

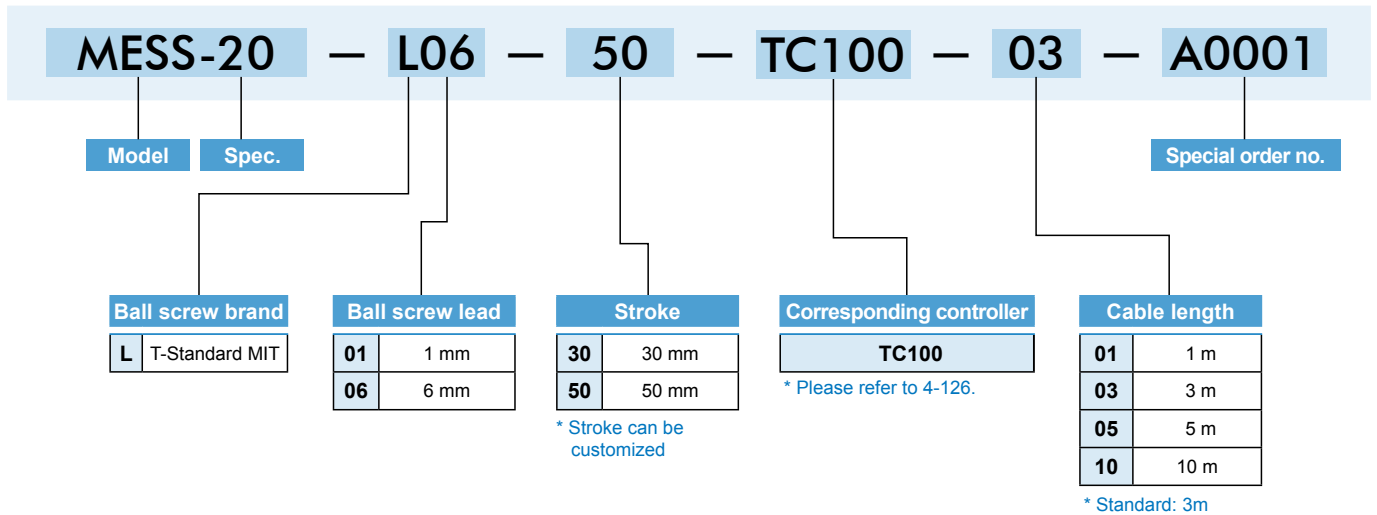

Order example of controller

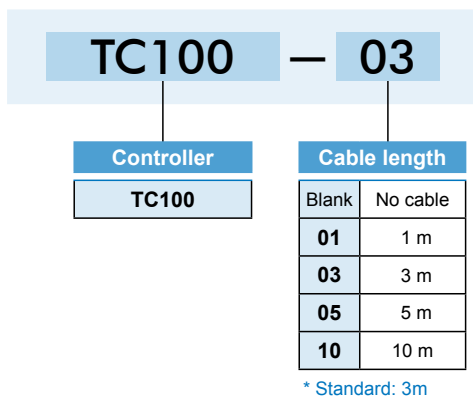

Speed-payload curve diagram

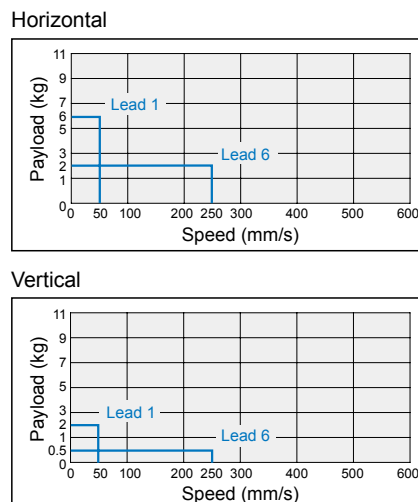

MESS-20 Dimensions

MINIATURE ELECTRIC CYLINDER (WITH MOTOR)



mindman

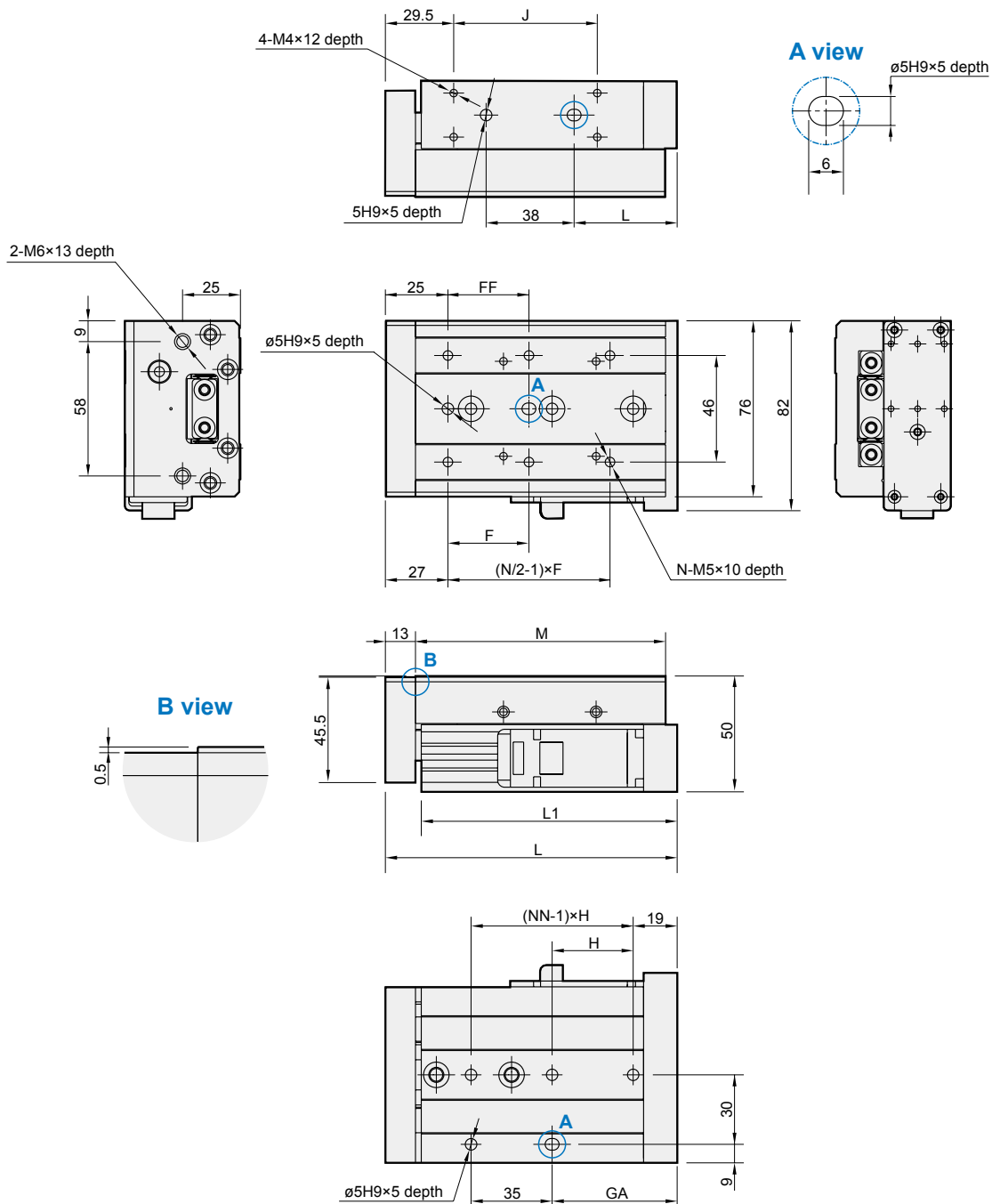

Unit: mm

Stroke	L	L1	F	FF	N	H	NN	GA	J	L	M	Weight(g)
30	101	85.5	50	40	4	45	2	29	37	19.5	83	1046
50	126	110.5	35	35	6	35	3	54	62	44.5	108	1495